



Name _____
 Date _____
 Track _____
 Weather & Temp _____
 Driver Mood _____

Tight Low Grip
 Medium Medium Grip
 Open High Grip
 Smooth Dusty
 Rough BlueGroove



BLACK EDITION

FRONT

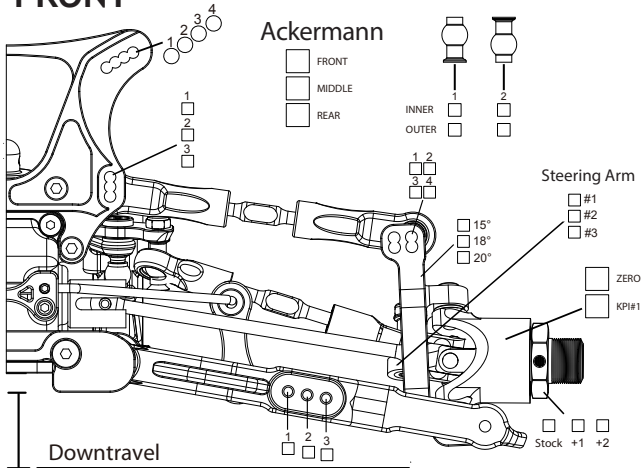

REAR

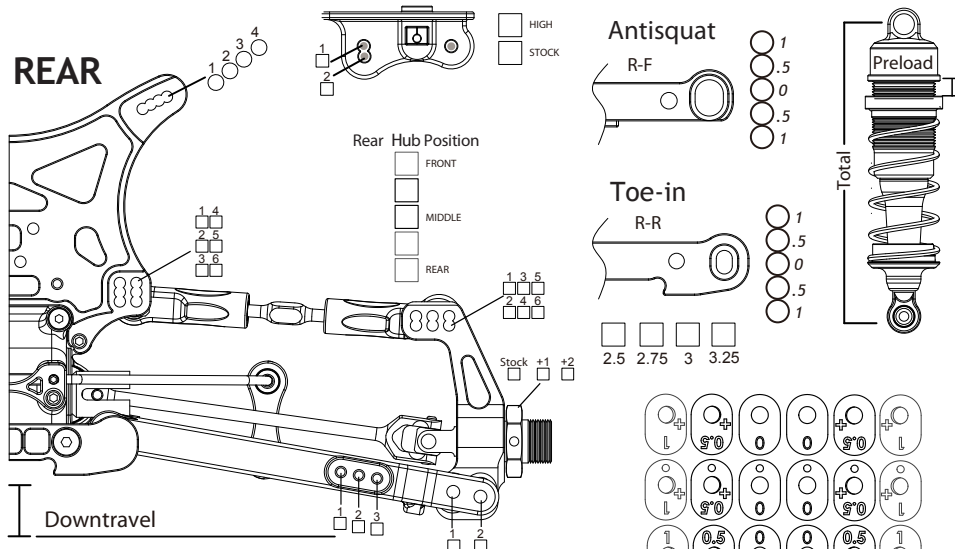

	FRONT	REAR
*		
Ride Height		
Downtravel With Tyres		
Swaybar		
Brake Balance	%	%
Camber	Length: mm	Length: mm
	Degree:	Degree:
Steering Link / Front Toe	Length: mm	
	Degree:	

SHOCKS

Oil wt / Brand		
Piston		
Spring		
Length	Preload: mm	Preload: mm
	Total: mm	Total: mm
Rebound		
Type	Emulsion <input type="checkbox"/>	Bladder <input type="checkbox"/>

TYRES

Tread / Brand		
Compound		
Insert		
Wheel		

DIFFS

	FRONT	CENTER	REAR
Oil wt / Brand			
Gear ratio (main/pinion)			

Car Weight **g**

Motor:

ESC:

Battery: Full Shorty Front Rear

Best Lapt ime
Runtime
Best result
Qualifying Position
Final Position

NOTES
