



BLACK EDITION

Name _____
 Date _____
 Track _____
 Weather & Temp _____
 Driver Mood _____

- Tight** **Low Grip**
Medium **Medium Grip**
Open **High Grip**
Smooth **Dusty**
Rough **BlueGroove**

FRONT

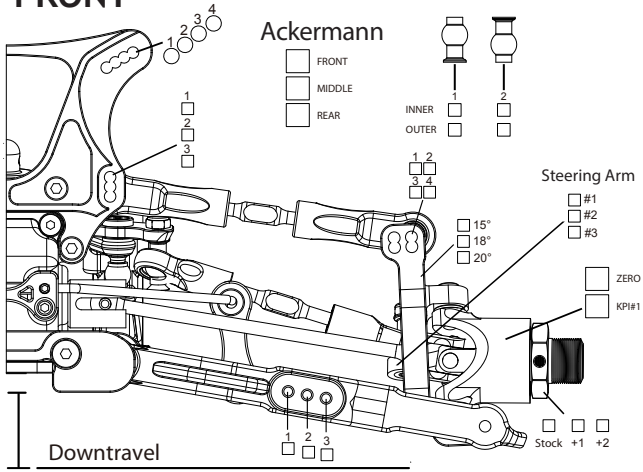

REAR

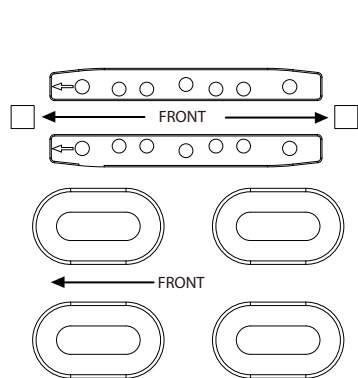
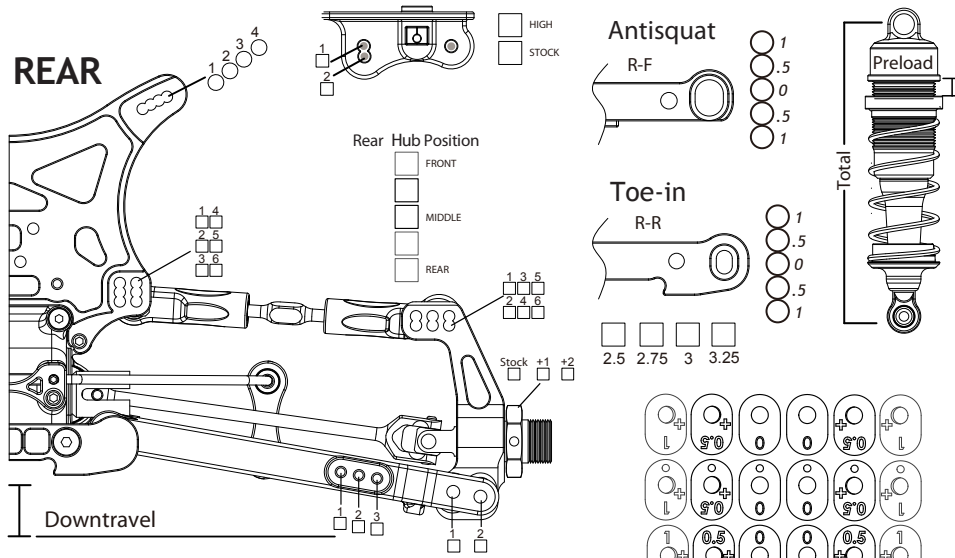

Car Weight _____ **g**

Engine	Plug	Fuel
Pipe	Clutch	Clutch Spring

	FRONT	REAR
*		
Ride Height		
Downtravel With Tyres		
Swaybar		
Brake Balance	%	%
Camber	Length: _____ mm	Length: _____ mm
	Degree: _____	Degree: _____
Steering Link / Front Toe	Length: _____ mm	
	Degree: _____	

SHOCKS

Oil wt / Brand		
Piston		
Spring		
Length	Preload: _____ mm	Preload: _____ mm
	Total: _____ mm	Total: _____ mm
Rebound		
Type	Emulsion <input type="checkbox"/>	Bladder <input type="checkbox"/>

TYRES

Tread / Brand		
Compound		
Insert		
Wheel		

DIFFS

	FRONT	CENTER	REAR
Oil wt / Brand			
Gear ratio (main/pinion)			

NOTES

Best Lapt ime _____
 Runtime _____
 Best result _____
 Qualifying Position _____
 Final Position _____