



BLACK EDITION

Name \_\_\_\_\_  
 Date \_\_\_\_\_  
 Track \_\_\_\_\_  
 Weather & Temp \_\_\_\_\_  
 Driver Mood \_\_\_\_\_

- Tight**    **Low Grip**  
**Medium**    **Medium Grip**  
**Open**    **High Grip**  
**Smooth**    **Dusty**  
**Rough**    **BlueGroove**

**FRONT**

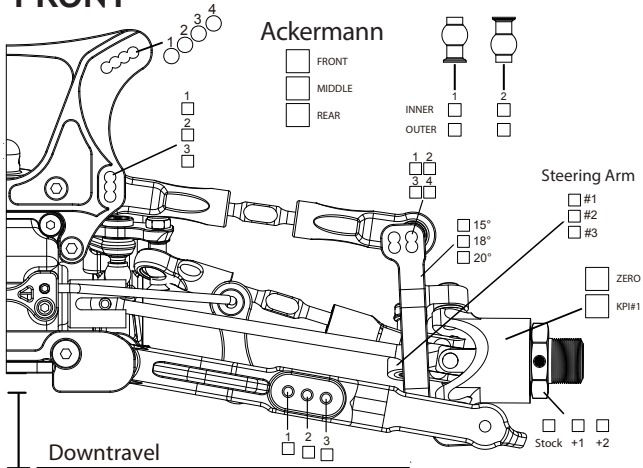

**REAR**

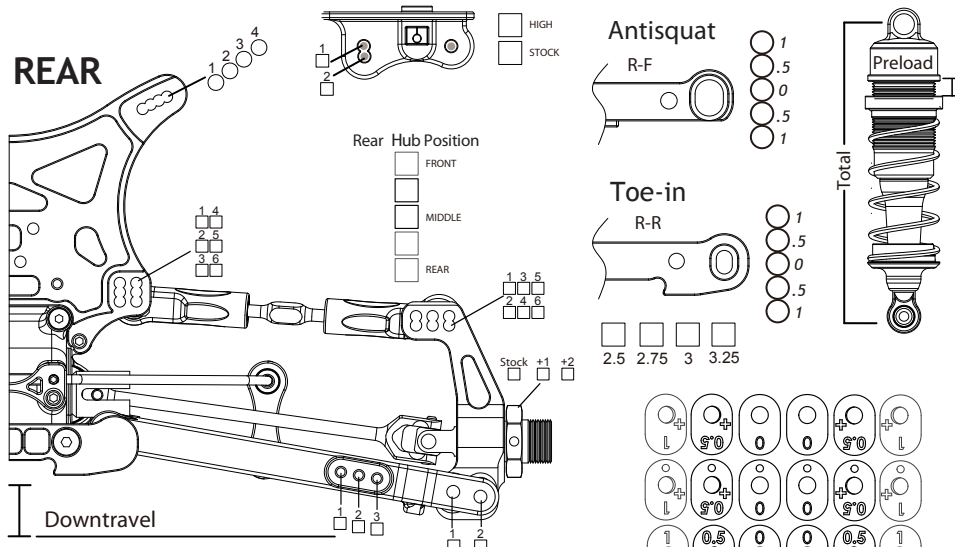

- Chassis  3mm  
 4mm

Part JQB \_\_\_\_\_

Car Weight \_\_\_\_\_ **g**

Engine	Plug	Fuel
Pipe	Clutch	Clutch Spring

**NOTES**

Best Lapt ime \_\_\_\_\_  
 Runtime \_\_\_\_\_  
 Best result \_\_\_\_\_  
 Qualifying Position \_\_\_\_\_  
 Final Position \_\_\_\_\_

	FRONT	REAR
<b>*</b>		
Ride Height		
Downtravel With Tyres		
Swaybar		
Brake Balance	%	%
Camber	Length: _____ mm	Length: _____ mm
	Degree: _____	Degree: _____
Steering Link / Front Toe	Length: _____ mm	
	Degree: _____	

**SHOCKS**

Oil wt / Brand		
Piston		
Spring		
Length	Preload: _____ mm	Preload: _____ mm
	Total: _____ mm	Total: _____ mm
Rebound		
Type	Emulsion <input type="checkbox"/>	Bladder <input type="checkbox"/>

**TYRES**

Tread / Brand		
Compound		
Insert		
Wheel		

**DIFFS**

	FRONT	CENTER	REAR
Oil wt / Brand			
Gear ratio (main/pinion)			

