



BLACK EDITION

Name _____
 Date _____
 Track _____
 Weather & Temp _____
 Driver Mood _____

- Tight** **Low Grip**
Medium **Medium Grip**
Open **High Grip**
Smooth **Dusty**
Rough **BlueGroove**

FRONT

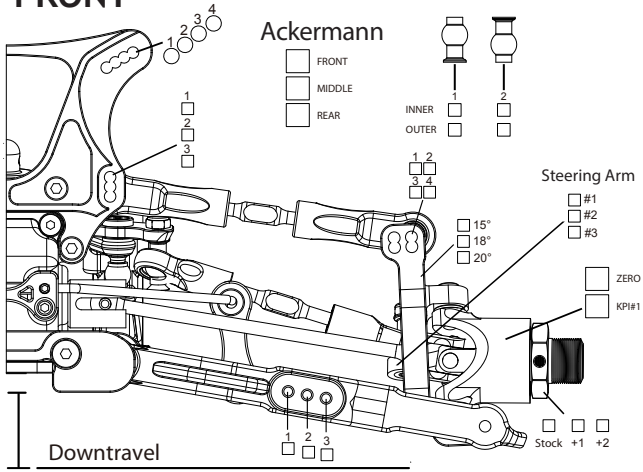

REAR

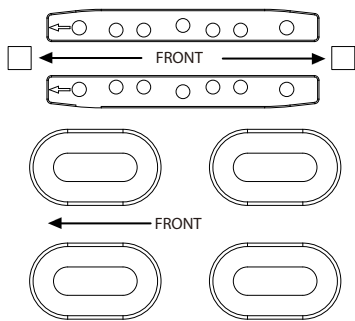
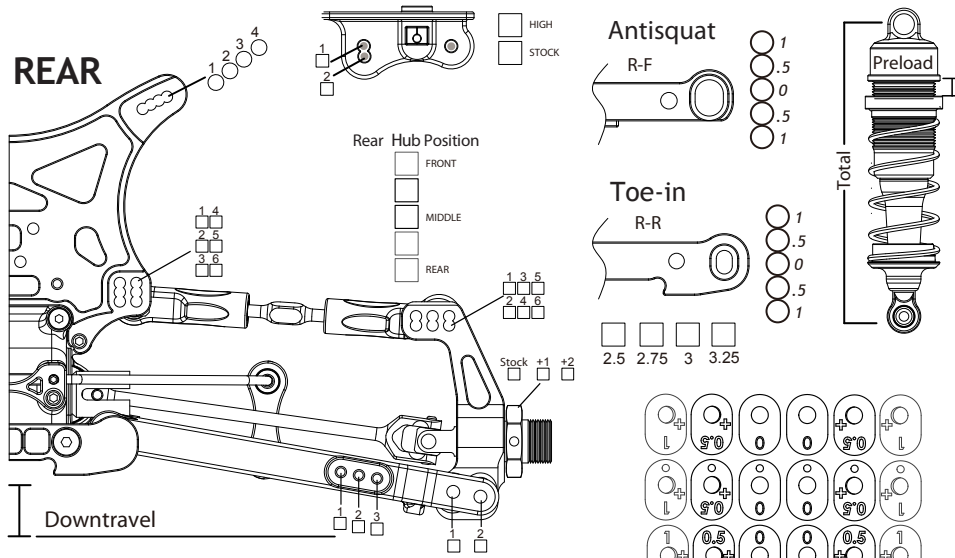

Car Weight _____ **g**

Engine	Plug	Fuel
Pipe	Clutch	Clutch Spring

NOTES

Best Lapt ime _____
 Runtime _____
 Best result _____
 Qualifying Position _____
 Final Position _____

	FRONT	REAR	
* Ride Height			
Downtravel With Tyres			
Swaybar			
Brake Balance	%	%	
Camber	Length: mm	Length: mm	
	Degree:	Degree:	
Steering Link / Front Toe	Length: mm		
	Degree:		
SHOCKS			
Oil wt / Brand			
Piston			
Spring			
Length	Preload: mm	Preload: mm	
	Total: mm	Total: mm	
Rebound			
Type	Emulsion <input type="checkbox"/>	Bladder <input type="checkbox"/>	
TYRES			
Tread / Brand			
Compound			
Insert			
Wheel			
DIFFS			
	FRONT	CENTER	REAR
Oil wt / Brand			
Gear ratio (main/pinion)			