

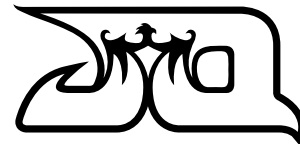

Name _____
 Date _____
 Track _____
 Weather & Temp _____
 Driver Mood _____

- Tight** **Low Grip**
- Medium** **Medium Grip**
- Open** **High Grip**
- Smooth** **Dusty**
- Rough** **BlueGroove**



FRONT

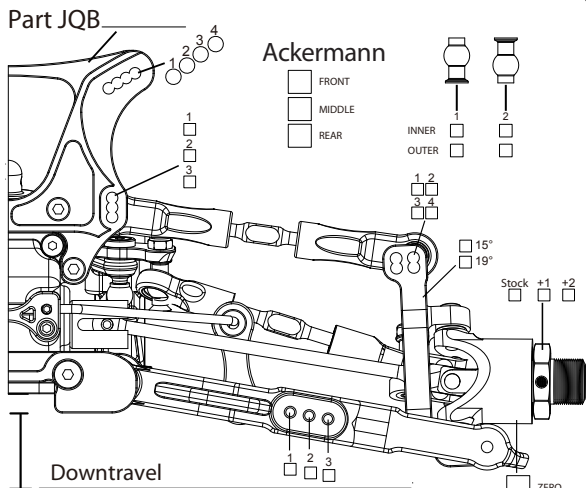

Kick-up

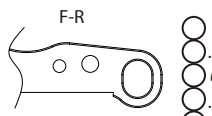
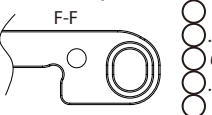

Antisquat

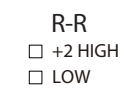
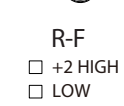
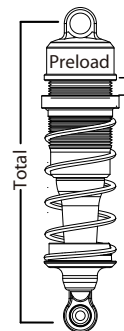
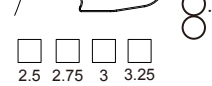
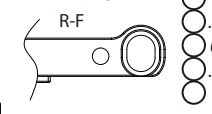

Toe-in R-R



Right

DEGREES

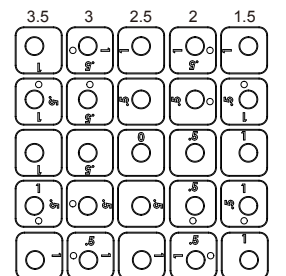

REAR

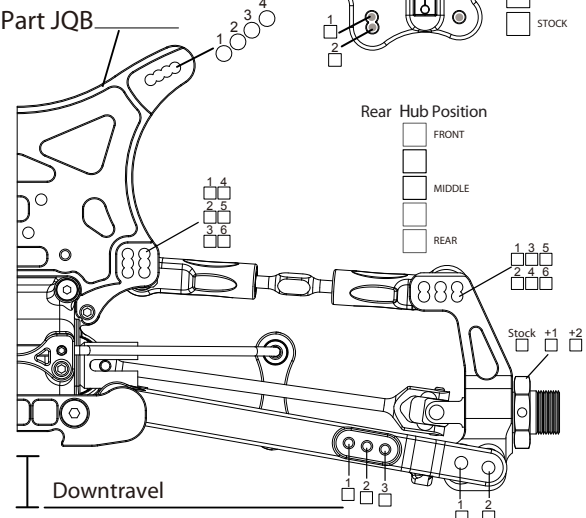

Chassis 3mm 4mm

Part JQB _____

Car Weight _____ **g**

Engine	Plug	Fuel
Pipe	Clutch	Clutch Spring

NOTES

Best Lapt ime
Runtime
Best result
Qualifying Position
Final Position

	FRONT	REAR
*		
Ride Height		
Downtravel With Tyres		
Swaybar		
Brake Balance	%	%
Camber	Length: _____ mm	Length: _____ mm
	Degree: _____	Degree: _____
Steering Link / Front Toe	Length: _____ mm	
	Degree: _____	

SHOCKS		
Oil wt / Brand		
Piston		
Spring		
Length	Preload: _____ mm	Preload: _____ mm
	Total: _____ mm	Total: _____ mm
Rebound		

TYRES		
Tread / Brand		
Compound		
Insert		
Wheel		
Tyre Set Weight		g

	FRONT	CENTER	REAR
Oil wt / Brand			
Gear ratio (main/pinion)			