



BLACK EDITION

Name \_\_\_\_\_  
 Date \_\_\_\_\_  
 Track \_\_\_\_\_  
 Weather & Temp \_\_\_\_\_  
 Driver Mood \_\_\_\_\_

- Tight**    **Low Grip**  
**Medium**    **Medium Grip**  
**Open**    **High Grip**  
**Smooth**    **Dusty**  
**Rough**    **BlueGroove**

**FRONT**

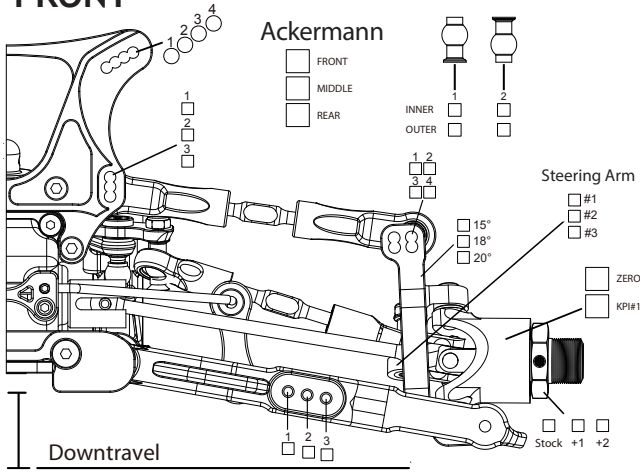

**REAR**

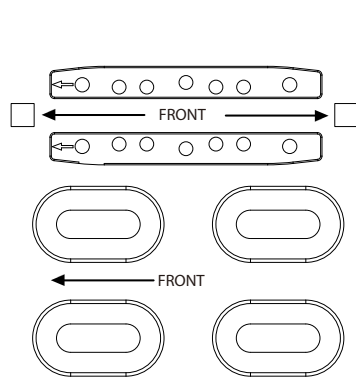
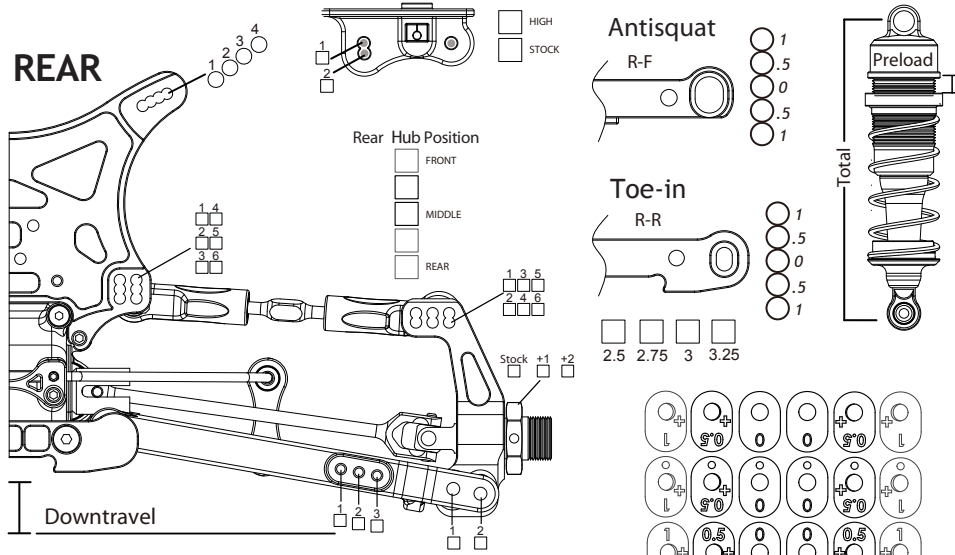

Car Weight \_\_\_\_\_ **g**

Engine	Plug	Fuel
Pipe	Clutch	Clutch Spring

**NOTES**

Best Lapt ime \_\_\_\_\_  
 Runtime \_\_\_\_\_  
 Best result \_\_\_\_\_  
 Qualifying Position \_\_\_\_\_  
 Final Position \_\_\_\_\_

	FRONT	REAR	
<b>* Ride Height</b>			
Downtravel With Tyres			
Swaybar			
Brake Balance	%	%	
Camber	Length: _____ mm	Length: _____ mm	
	Degree: _____	Degree: _____	
Steering Link / Front Toe	Length: _____ mm		
	Degree: _____		
<b>SHOCKS</b>			
Oil wt / Brand			
Piston			
Spring			
Length	Preload: _____ mm	Preload: _____ mm	
	Total: _____ mm	Total: _____ mm	
Rebound			
Type	Emulsion <input type="checkbox"/>	Bladder <input type="checkbox"/>	
<b>TYRES</b>			
Tread / Brand			
Compound			
Insert			
Wheel			
<b>DIFFS</b>			
	FRONT	CENTER	REAR
Oil wt / Brand			
Gear ratio (main/pinion)			