

**Reset**

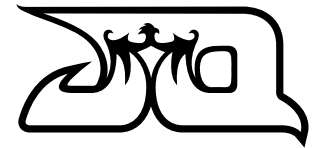

Name Jason Stump  
 Date 1/13/18  
 Track Adelanto  
 Weather & Temp 70f Breezy  
 Driver Mood Hyper/twitchy

Tight    Low Grip  
 Medium  Medium Grip  
 Open    High Grip  
 Smooth  Dusty  
 Rough     BlueGroove



**FRONT**

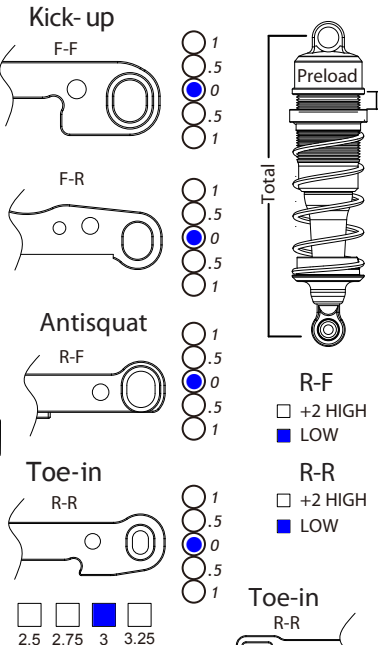
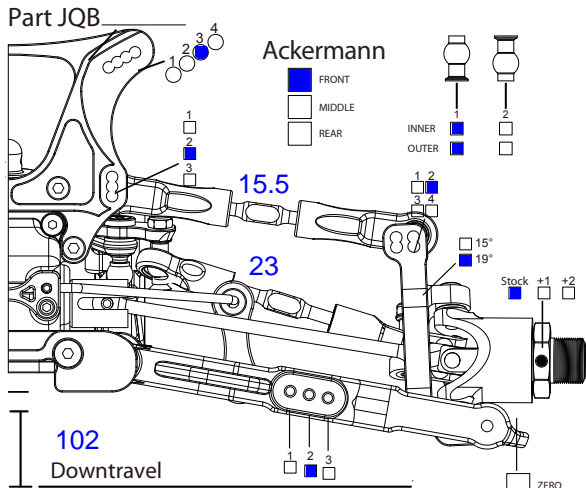

**REAR**

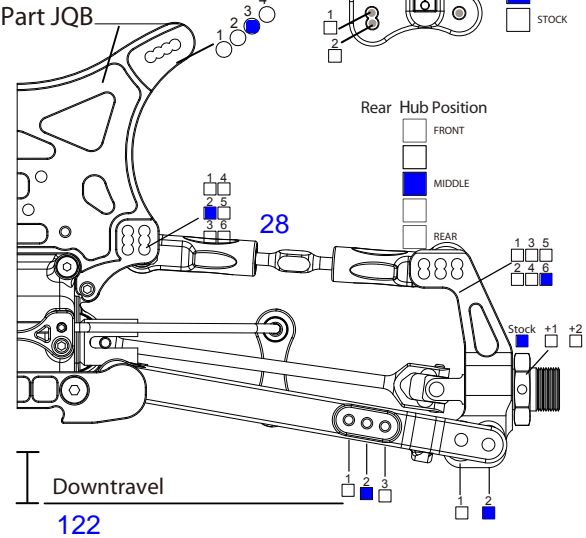

	FRONT	REAR
Ride Height	27	26
Downtravel With Tyres	102	122
Swaybar	stock	stock
Brake Balance	%	%
Camber	Length: 15.5 mm Degree:	Length: 28 mm Degree:
Steering Link / Front Toe	Length: 23 mm Degree:	

**SHOCKS**

Oil wt / Brand	27.5 AE	27.5 AE
Piston	7h 1.2	7h 1.4
Spring	stock	stock
Length	Preload: mm Total: mm	Preload: mm Total: mm
Rebound	0 w/bladder	0 w/bladder

**TYRES**

Tread / Brand	PL holeshot	
Compound	m3	
Insert	PL	
Wheel	PL	
Tyre Set Weight		<b>g</b>

**DIFFS**

	FRONT	CENTER	REAR
Oil wt / Brand	12 AE	15 AE	4 AE
Gear ratio (main/pinion)			

Car Weight **g**

Motor: Tekin  
 ESC: HW  
 Battery: 4 cell

Best Lapt ime
Runtime
Best result
Qualifying Position
Final Position

**NOTES**