

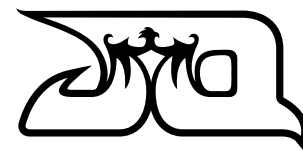

Name _____
 Date _____
 Track _____
 Weather & Temp _____
 Driver Mood _____

Tight
Medium
Open
Smooth
Rough

Low Grip
Medium Grip
High Grip
Dusty
BlueGroove



FRONT

Part JQB _____

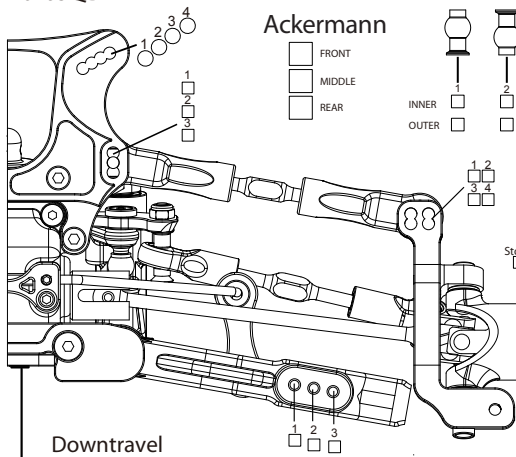

Kick-up

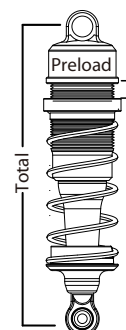
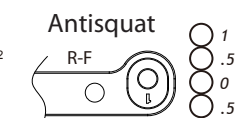
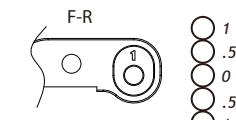
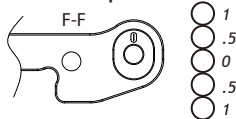

R-F
 LOW
 +2 HIGH

R-R
 LOW
 +2 HIGH

REAR

Part JQB _____

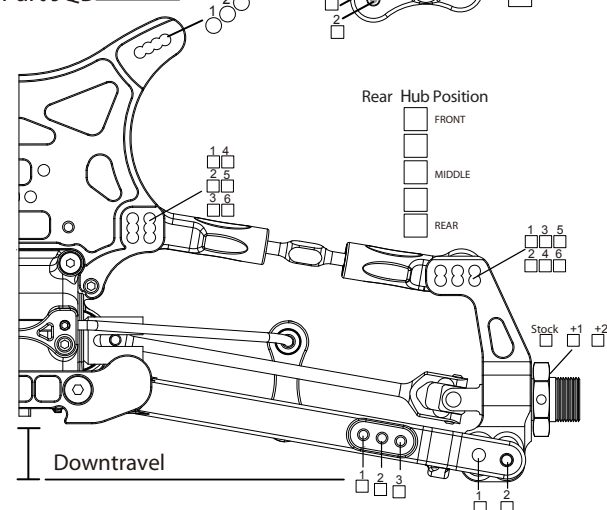

Toe-in

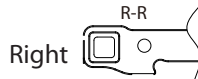

DEGREES

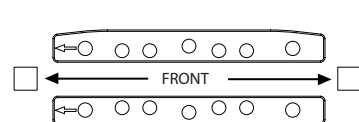
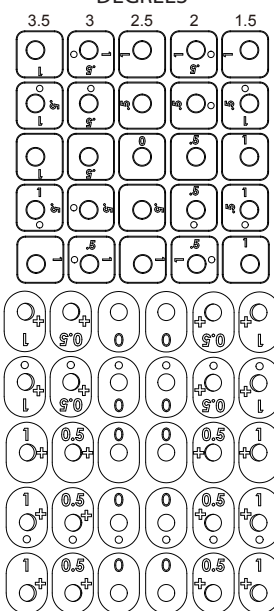

Chassis 3mm
 4mm

Part JQB _____

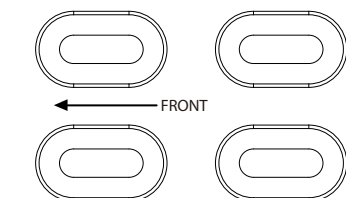

Car Weight _____



Engine _____

Plug _____

Fuel _____

Pipe _____

Clutch _____

Clutch Spring _____

	FRONT	REAR
*		
Ride Height		
Downtravel		
Swaybar		
Brake Balance	%	%
Camber	Length: _____ mm Degree: _____	Length: _____ mm Degree: _____
Steering Link / Front Toe	Length: _____ mm Degree: _____	

SHOCKS

Oil wt / Brand		
Piston		
Spring		
Length	Preload: _____ mm Total: _____ mm	Preload: _____ mm Total: _____ mm
Rebound		

TYRES

Tread / Brand		
Compound		
Insert		
Wheel		
Tyre Set Weight		g

DIFFS

	FRONT	CENTER	REAR
Oil wt / Brand			
Gear ratio (main/pini on)			

Best Lap time
Runtime
Best result
Qualifying Position
Final Position

NOTES
